

SOUND TECHNICAL RIDER

La Vieille Ecole

Date of Gig :
Place of Gig :

Contact : Franck at 06 74 39 70 23

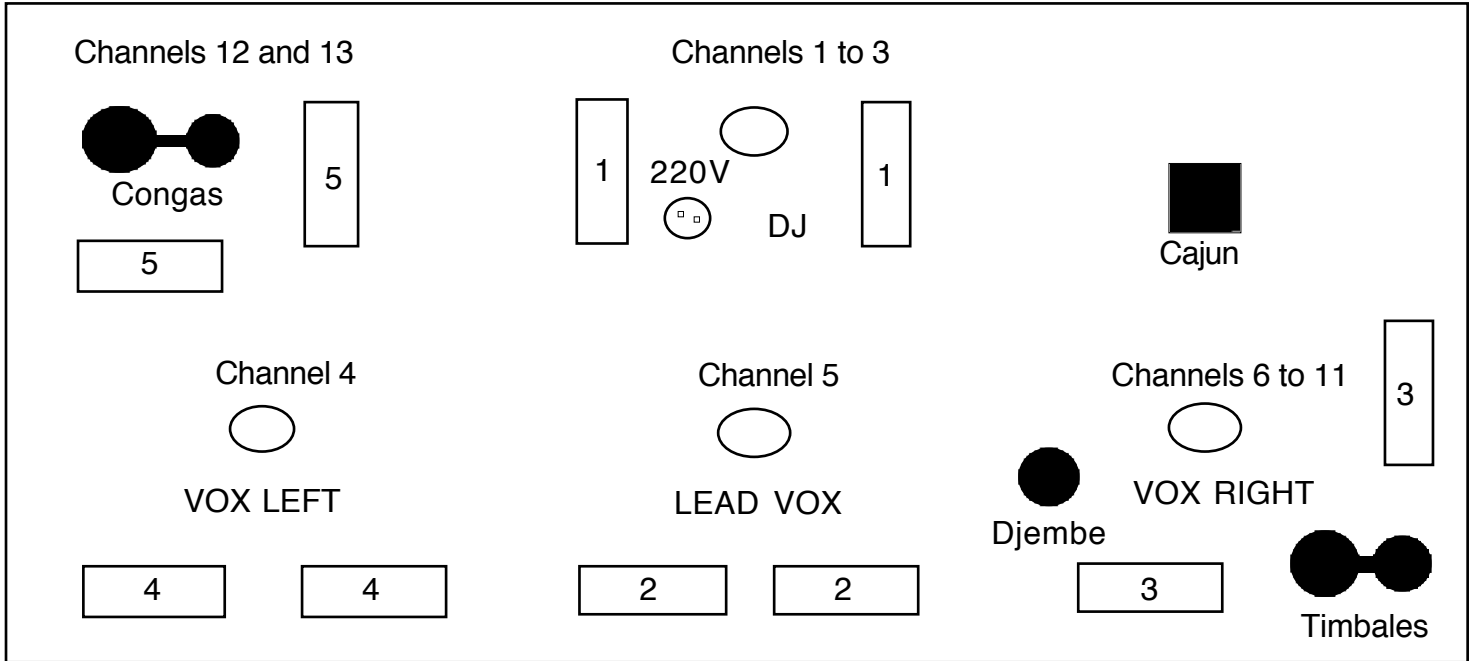

**Prévoir un praticable de 31,5 inches Height at least for the DJ Kit
ainsi qu'un espace fonds de scène d'environ 8,20 feet length and 6,56 feet height**

PATCHLIST

FOH :

1Kw for 100 people / 105 dB at mixing console
(for open air take contact)
Meyer, EAW, Heil, EV, filtered system.

Mixing Console F.O.H :

In the venue, middled, 2/3 from the stage.
16 x channels at least with 4 x EQ
2 x AUX (+ 4 x AUX if monitoring from mixing console)
1 x Stereo Compressor (Behringer accepted)
1 x EQ 2*31 frequencies.

Stage monitor mixer and monitors :

At least 16 channels
5 channels with 5 x EQ 31 frequencies
Meyer, EAW, Heil, EV.

Effects :

1 x Tap Delay unit
1 x Reverb unit Lexicon / T.C/ Yamaha

Inserts :

5 x Compressors and monitors
if possible (Behringer accepted)

Signature of local sound engineer :

Channels	Mic	Inserts
1 - Platine CD	D.I. Box	C
2 - Platine CD	D.I. Box	C
3 - Vox DJ	SM 58	C
4 - Vox Left	H.F	C
5- Vox Lead	H.F	C
6 - Vox Right	H.F	C
7 - Timbales L	EV 408 / SM 57	
8 - Timbales R	EV 408 / SM 57	
9 - Ambiance Perc	KM 184 / C 460	
10 - Djembé	EV 408 / SM 57	
11 - Cajun	EV 408 / SM 57	
12 -Congas L	EV 408 / SM 57	
13 - Congas R	EV 408 / SM 57	